

1-PC BALL VALVE THREAD END

一片式内螺纹球阀



特点 Features

- Reduced port, 1/4"~4" (DN6~DN100)
- W.P.: 1000WOG (PN63)
- W.T.: -20°C~180°C
- Investment casting
- Blow-out proof stem
- Thread type: ASME B1.20.1 (NPT), BSP BSPT
DIN 259 / DIN 2999, BS 21,
ISO 288-1, ISO 7-1

材料表 Material List

序号No.	零件 PARTS	材料 MATERIAL		
1	阀体 BODY	WCB	CF8	CF8M
2	阀座 SEAT	PTFE		
3	球体 BALL	CF8	CF8	CF8M
4	垫片 GASKET	PTFE		
5	阀盖 BONNET	WCB	CF8	CF8M
6	阀杆 STEM	304	304	316
7	阀杆垫圈 STEM WASHER	PTFE		
8	填料 PACKING	PTFE		
9	垫圈 WASHER	304		
10	手柄 HANDLE	304+PVC		
11	弹簧垫圈 SPRING WASHER	304		
12	螺母 NUT	304		

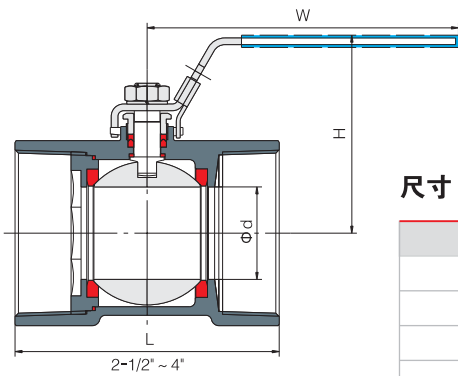
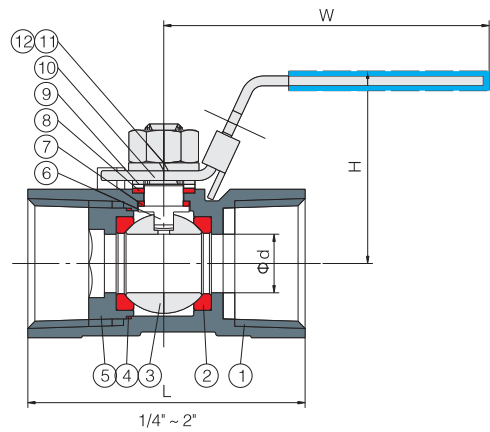

尺寸 Dimensions

Unit: mm

尺寸 SIZE		d	L	H	W
1/4"	DN6	5	40.5	36	80
3/8"	DN10	7	43.5	38	80
1/2"	DN15	9	53	42	110
3/4"	DN20	12	57.5	46	110
1"	DN25	15	70	49	115
1-1/4"	DN32	20	76	54	115
1-1/2"	DN40	25	81.5	62	160
2"	DN50	32	93	69	160
2-1/2"	DN65	38	112	85	190
3"	DN80	50	132	96	220
4"	DN100	65	185	122	250

1-PC HEX BALL VALVE THREAD END

一片式内六角螺纹球阀



特点 Features

- Reduced port, 1/2"~2" (DN15~DN50)
- W.P.: 2000WOG (PN150)
- W.T.: -20°C~180°C
- Blow-out proof stem
- NACE MR0175
- Locking device handle (option)
- Thread type: ASME B1.20.1 (NPT),
DIN 259 / DIN 2999, BS 21,
ISO 288-1, ISO 7-1

材料表 Material List

序号No.	零件 PARTS	材料 MATERIAL		
1	阀体 BODY	A105	F304	F316
2	阀座 SEAT	RPTFE		
3	球体 BALL	CF8	CF8	CF8M
4	阀座 SEAT	RPTFE		
5	垫圈 WASHER	304	304	316
6	阀盖 BONNET	304	304	316
7	阀杆 STEM	304	304	316
8	阀杆垫圈 STEM WASHER	PTFE		
9	填料 PACKING	PTFE		
10	填料盖 GLAND	304		
11	手柄 HANDLE	304+PVC		
12	弹簧垫圈 SPRING WASHER	304		
13	螺母 NUT	304		

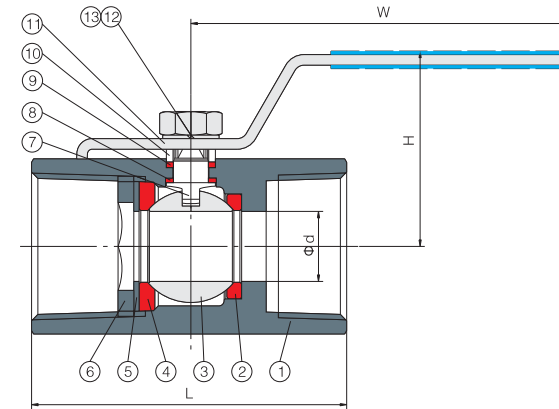

尺寸 Dimensions

Unit: mm

尺寸 SIZE		d	L	H	W
1/2"	DN15	9	62	53	120
3/4"	DN20	12	70	56	120
1"	DN25	15	86	58	135
1-1/4"	DN32	20	93	60	150
1-1/2"	DN40	25	102	63	150
2"	DN50	32	114	66	160